

Report Number: QIP- ASI132452

Audit Date : 15 Apr., 2013
Expiry Date : 14 Apr., 2014

This report is issued by Focus Technology Co., Ltd. (Made-in-China.com) and the supervising inspectorate (SGS-CSTC Standards Technical Services Co., Ltd.) to confirm that:

Company Name : Guangdong Guanchang Steel Co., Ltd.
 广东冠昌钢业有限公司
Showroom : <http://zcysteel.en.made-in-china.com/>
Address : Kalingpian, Daxi Economic Cooperation Association, Meiyun Town, Jieyang City, Guangdong Province, China
Product : Stainless Steel Coil, Stainless Steel Sheet, Stainless Steel Strip, Stainless Circle

has been on site audited for the Following Scope of Activity

1. General Information
2. Foreign Trade Capacity
3. Production Capacity & Quality Control
4. Photos



General Comments:

Guangdong Guanchang Steel Co., Ltd. is a manufacturer with 106 employees; it was established in 2007, located in Kalingpian, Daxi Economic Cooperation Association, Meiyun Town, Jieyang City, Guangdong Province, China. The workshops occupy an area of more than 11,000 square meters. Guangdong Guanchang Steel Co., Ltd. has successful foreign trading experience in Europe, Mideast and Asia.



Sign for and on behalf of
 SGS-CSTC Standards Technical Services Co., Ltd.

This document is issued by the Company under its General Conditions of Service accessible at http://www.sgs.com/terms_and_conditions.htm. Attention is drawn to the limitation of liability, indemnification and jurisdiction issues defined therein. Any holder of this document is advised that information contained hereon is solely limited to visual examination of the safely and readily accessible portions of the consignment and reflects the Company's findings at the time of its intervention only and within the limits of Client's instructions, if any. The Company's sole responsibility is to its Client and this document does not exonerate parties to a transaction from exercising all their rights and obligations under the transaction documents. Any unauthorized alteration, forgery or falsification of the content or appearance of this document is unlawful and offenders may be prosecuted to the fullest extent of the law.

Attention: To check the authenticity of testing /inspection report & certificate, please contact us at telephone: (86-755)83071443, or email: CN.Doccheck@sgs.com

Page No.: 1 of 11

SUPPLIER ASSESSMENT REPORT

Audited Company	Guangdong Guanchang Steel Co., Ltd. 广东冠昌钢业有限公司
Audited Site:	Kalingpian, Daxi Economic Cooperation Association, Meiyun Town, Jieyang City, Guangdong Province, China

Consigner of Assessment	Made-in-China.com		
Audit Type	<input checked="" type="checkbox"/> Initial Audit <input type="checkbox"/> Re-audit		
Valid Date	From 15 Apr., 2013 to 14 Apr., 2014	Verify Report	www.sgs.com
Auditor	Donny Dong	Reviewed by	Roger Wang

CONTENTS

- Part A: General Information**
 - Section 1: Company Overview
 - Section 2: Human Resources
- Part B: Foreign Trade Capacity**
 - Section 1: Export Overall Situation
 - Section 2: Export Business Capacity
 - Section 3: Supplier Management
 - Section 4: After-sales Service Capacity
- Part C: Product Research & Development Capacity**
 - Section 1: Product Research & Development Capacity
- Part D: Management System and Product Certification**
 - Section 1: Management System(s) and Product Certification
- Part E: Production Capacity & Quality Control**
 - Section 1: Production Capacity Section
 - Section 2: Production Process Control
- Part F: Financial Position**
 - Section 1: Financial Data
 - Section 2: Key Performance Indications
 - Section 3: Banking
 - Section 4: Product Insurance
- Part G: Working Environment**
 - Section 1: Working Environment
- Part H: Energy Saving and Emission Reduction**
 - Section 1: Environmental Management
 - Section 2: Water, Gas and Noise Control
- Part I: Industry Information**
 - Section 1: Industry Information
- Part J: Photos**
 - Section 1: Photos of Documents
 - Section 2: Photos of Company

This document is issued by the Company under its General Conditions of Service accessible at http://www.sgs.com/terms_and_conditions.htm. Attention is drawn to the limitation of liability, indemnification and jurisdiction issues defined therein. Any holder of this document is advised that information contained hereon is solely limited to visual examination of the safely and readily accessible portions of the consignment and reflects the Company's findings at the time of its intervention only and within the limits of Client's instructions, if any. The Company's sole responsibility is to its Client and this document does not exonerate parties to a transaction from exercising all their rights and obligations under the transaction documents. Any unauthorized alteration, forgery or falsification of the content or appearance of this document is unlawful and offenders may be prosecuted to the fullest extent of the law.

Attention: To check the authenticity of testing /inspection report & certificate, please contact us at telephone: (86-755)83071443, or email: CN.Doccheck@sgs.com

Page No.: 2 of 11



Part A: General Information

Section 1: Company Overview

1.1 Legal Validity			
Does the company have a valid business license?	<input checked="" type="checkbox"/> Yes <input type="checkbox"/> No <input type="checkbox"/> Others	Registration Number	445200000026029
Year of established	07 Mar., 2007	Valid Date	Long-term
Registered address	Kalingpian, Daxi Economic Cooperation Association, Meiyun Town, Jieyang City, Guangdong Province, China		
Actual address	Kalingpian, Daxi Economic Cooperation Association, Meiyun Town, Jieyang City, Guangdong Province, China		
Is the annual review done by local authority (Industrial & Commercial Bureau)?	Refer to business license provided; it was reviewed in year 2013.		
Registered capital	RMB 10,890,000		
Paid-in capital	RMB 10,890,000		
Name of legal representative	Mr. Chubin Chen		
Business scope	Production and sales of stainless steel products, metal products, auto spare parts, household appliances, electronic products and accessories, inverter, toys; Sales of metal material, building material, chemical material, plastic products, solar battery; R&D of computer software/hardware; Goods and technology import and export. (except for laws, administrative regulations prohibited items; Items prohibited before operation)		
1.2 Basic Information			
Contact person	Mr. Eddy Huang	Email	crown.china@hotmail.com
Phone number	0086-663-8899788 0086-18902769699	Fax number	0086-663-8899799
URL/Web address	Nil		
Company type	<input checked="" type="checkbox"/> Manufacturer <input type="checkbox"/> Trading Company <input type="checkbox"/> Combined <input type="checkbox"/> Group Corporation		
Type of ownership	<input checked="" type="checkbox"/> Limited Company <input type="checkbox"/> Public Company <input type="checkbox"/> Foreign joint venture <input type="checkbox"/> State-Owned <input type="checkbox"/> Private Owner <input type="checkbox"/> Wholly foreign-owned enterprises		
Subsidiary company	Nil		
Products manufactured / sold scope	Stainless Steel Coil, Stainless Steel Sheet, Stainless Steel Strip, Stainless Circle		
1.3 Company Building Information			
According to: <input type="checkbox"/> Land certificate <input type="checkbox"/> Real estate certificate <input type="checkbox"/> Lease agreement <input checked="" type="checkbox"/> Observation Estimated on site The company area 11000 square meters The land occupies square meters. The offices occupy square meters. The workshops occupy 11000 square meters.			

This document is issued by the Company under its General Conditions of Service accessible at http://www.sgs.com/terms_and_conditions.htm. Attention is drawn to the limitation of liability, indemnification and jurisdiction issues defined therein. Any holder of this document is advised that information contained hereon is solely limited to visual examination of the safely and readily accessible portions of the consignment and reflects the Company's findings at the time of its intervention only and within the limits of Client's instructions, if any. The Company's sole responsibility is to its Client and this document does not exonerate parties to a transaction from exercising all their rights and obligations under the transaction documents. Any unauthorized alteration, forgery or falsification of the content or appearance of this document is unlawful and offenders may be prosecuted to the fullest extent of the law.

Attention: To check the authenticity of testing /inspection report & certificate, please contact us at telephone: (86-755)83071443, or email: CN.Doccheck@sgs.com

Page No.: 3 of 11



Section 2: Human Resources

2.1 Company Chart

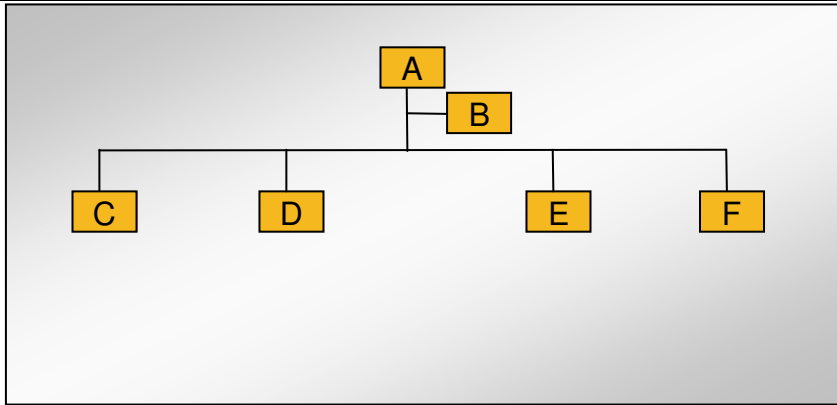

2.2 Explanation of Code and Employee Details

Code	Department	Number of employees
A	General Manager	1
B	Vice General Manager	1
C	Financial Dept.	3
D	Sales Dept.	8
E	Production Dept.	90
F	HR	3
Number in total:		106

2.3 Key Staff

Title	Full name	Education	Working experience for this trade / total experience
General Manager	Mr. Chubin Chen	College	15 Years/15 Years
Manager of Foreign Trade Dept.	Mr. Eddy Huang	University	5 Years/5 Years

Remark: Above information of key staff was based on interview with company representative.

This document is issued by the Company under its General Conditions of Service accessible at http://www.sgs.com/terms_and_conditions.htm. Attention is drawn to the limitation of liability, indemnification and jurisdiction issues defined therein. Any holder of this document is advised that information contained hereon is solely limited to visual examination of the safety and readily accessible portions of the consignment and reflects the Company's findings at the time of its intervention only and within the limits of Client's instructions, if any. The Company's sole responsibility is to its Client and this document does not exonerate parties to a transaction from exercising all their rights and obligations under the transaction documents. Any unauthorized alteration, forgery or falsification of the content or appearance of this document is unlawful and offenders may be prosecuted to the fullest extent of the law.

Attention: To check the authenticity of testing /inspection report & certificate, please contact us at telephone: (86-755)83071443, or email: CN.Doccheck@sgs.com



Part B: Foreign Trade Capacity

Section 1: Export Overall Situation

1.1 Export Overall Situation	
Does the company have a valid Import and Export license?	<input type="checkbox"/> Yes <input checked="" type="checkbox"/> No
The import and export enterprise code.	Nil
The number of foreign trading staff with relevant trading experience.	<input type="checkbox"/> within 1 year staff <input checked="" type="checkbox"/> 1-5 years 4 staffs <input type="checkbox"/> 6-10 years staff <input type="checkbox"/> over 10 years staff Total 4 staff
The language freely used by foreign trade staff	<input checked="" type="checkbox"/> English <input type="checkbox"/> others
Annual revenue of previous year	Refer to related records; this revenue was RMB 80 million in year 2012.
Annual export revenue of previous year	Nil
Estimated export revenue for this year.	Based on interview with Mr. Huang; the estimated export revenue was USD 15 million in this year.
Overseas agent / branch	<input type="checkbox"/> Yes <input checked="" type="checkbox"/> No
Nearest port	Yantian Port, Shenzhen City
Acceptable quotation terms	<input checked="" type="checkbox"/> FOB <input checked="" type="checkbox"/> CIF <input checked="" type="checkbox"/> CFR
Acceptable payment terms	<input checked="" type="checkbox"/> LC <input checked="" type="checkbox"/> T/T <input checked="" type="checkbox"/> D/P <input type="checkbox"/> PayPal <input type="checkbox"/> Western Union <input type="checkbox"/> Small-amount payment
Average lead time (Peak Season)	<input type="checkbox"/> within 15 workday <input checked="" type="checkbox"/> one month <input type="checkbox"/> 2-3 months <input type="checkbox"/> 4-6 months <input type="checkbox"/> 6-12 months <input type="checkbox"/> more time
Average lead time (Off Season)	<input checked="" type="checkbox"/> within 15 workday <input type="checkbox"/> one month <input type="checkbox"/> 2-3 months <input type="checkbox"/> 4-6 months <input type="checkbox"/> 6-12 months <input type="checkbox"/> more time

Section 2: Export Business Capacity

2.1 Market Distribution (please list top three areas)		
Market	Main Product	Main client
<input type="checkbox"/> North America		
<input type="checkbox"/> South America		
<input checked="" type="checkbox"/> Europe	Stainless Steel Coil, Stainless Steel Sheet, Stainless Steel Strip, Stainless Circle	Nil
<input checked="" type="checkbox"/> Southeast Asia/ Mideast	Stainless Steel Coil, Stainless Steel Sheet, Stainless Steel Strip, Stainless Circle	Nil
<input type="checkbox"/> Africa		
<input type="checkbox"/> East Asia (Japan/ South Korea)		
<input type="checkbox"/> Australia		
<input checked="" type="checkbox"/> Domestic	Stainless Steel Coil, Stainless Steel Sheet, Stainless Steel Strip, Stainless Circle	Nil
<input type="checkbox"/> Others		

This document is issued by the Company under its General Conditions of Service accessible at http://www.sgs.com/terms_and_conditions.htm. Attention is drawn to the limitation of liability, indemnification and jurisdiction issues defined therein. Any holder of this document is advised that information contained hereon is solely limited to visual examination of the safely and readily accessible portions of the consignment and reflects the Company's findings at the time of its intervention only and within the limits of Client's instructions, if any. The Company's sole responsibility is to its Client and this document does not exonerate parties to a transaction from exercising all their rights and obligations under the transaction documents. Any unauthorized alteration, forgery or falsification of the content or appearance of this document is unlawful and offenders may be prosecuted to the fullest extent of the law.

Attention: To check the authenticity of testing /inspection report & certificate, please contact us at telephone: (86-755)83071443, or email: CN.Doccheck@sgs.com

Page No.: 5 of 11



Section 3: Supplier Management

3.1 Supplier Management		
Item	Content	Observations /Comments
1	Does the company establish and implement an effective suppliers' assessment procedure?	<input type="checkbox"/> Have the written procedures and followed records <input checked="" type="checkbox"/> Have the written procedures but no records <input type="checkbox"/> Have relevant records without written procedure <input type="checkbox"/> No written procedures or followed records
2	Does the company have an updated list of approved suppliers?	<input type="checkbox"/> The approved suppliers list was updated in _____ <input type="checkbox"/> Have the written suppliers without approved signature or date. <input checked="" type="checkbox"/> Provided some suppliers names <input type="checkbox"/> No approved suppliers list

Section 4: After-sales Service Capacity

4.1 After-sales Service Capacity		
Item	Content	Observations /Comments
1	Is there a procedure to conduct random product inspection after final packaging in place?	<input type="checkbox"/> Have clear standards and written inspection records <input type="checkbox"/> No written standards but had inspection reports <input type="checkbox"/> Have the procedures but no inspection records <input checked="" type="checkbox"/> It's not necessary to carry out the inspection
2	Is there a clear procedure for handling customer complaints?	<input type="checkbox"/> Has the clear procedure and followed records <input checked="" type="checkbox"/> Has the procedure but no written records. <input type="checkbox"/> No written procedures or records.
3	Can the finished/package product be traced by lot identification to the appropriate raw materials test reports?	<input type="checkbox"/> Have the procedures to trace the raw materials. <input type="checkbox"/> Can trace main materials <input type="checkbox"/> Can trace production date. <input checked="" type="checkbox"/> Can't trace products
4	Are corrective & preventive actions mechanism established and implemented effectively (including the suppliers/ sub-contractors control, incoming inspection, process control, final inspection and customer complaint)?	<input type="checkbox"/> Has the clear procedure and followed records <input checked="" type="checkbox"/> Has the procedure but no written records. <input type="checkbox"/> No written procedures or records.





This document is issued by the Company under its General Conditions of Service accessible at http://www.sgs.com/terms_and_conditions.htm. Attention is drawn to the limitation of liability, indemnification and jurisdiction issues defined therein. Any holder of this document is advised that information contained hereon is solely limited to visual examination of the safely and readily accessible portions of the consignment and reflects the Company's findings at the time of its intervention only and within the limits of Client's instructions, if any. The Company's sole responsibility is to its Client and this document does not exonerate parties to a transaction from exercising all their rights and obligations under the transaction documents. Any unauthorized alteration, forgery or falsification of the content or appearance of this document is unlawful and offenders may be prosecuted to the fullest extent of the law.

Attention: To check the authenticity of testing /inspection report & certificate, please contact us at telephone: (86-755)83071443, or email: CN.Doccheck@sgs.com

Part E: Production Capacity & Quality Control

Section 1: Production Capacity



1.1 Production Workflow Chart

	→		→		→
Raw materials		Slitting		Rolling	
	→				
Annealing		Packed products			

1.2 Products Situation (Top three Product Categories)

Product	Price range	Min. order quantity	Top monthly output	Average monthly output	Total in 2012
 Stainless Steel Sheet	8000-9000 Yuan/T	10 T	5000 T	3000 T	36000 T

1.3 Main Facilities

Picture	Facility name	Brand or Country/Region of origin	Target Value/machine*day	Quantity
	Slitting Machine	China Mainland	300 T	1 set
	Rolling Machine	China Mainland	200 T	15 sets
	Annealing Machine	China Mainland	200 T	11 sets

This document is issued by the Company under its General Conditions of Service accessible at http://www.sgs.com/terms_and_conditions.htm. Attention is drawn to the limitation of liability, indemnification and jurisdiction issues defined therein. Any holder of this document is advised that information contained hereon is solely limited to visual examination of the safely and readily accessible portions of the consignment and reflects the Company's findings at the time of its intervention only and within the limits of Client's instructions, if any. The Company's sole responsibility is to its Client and this document does not exonerate parties to a transaction from exercising all their rights and obligations under the transaction documents. Any unauthorized alteration, forgery or falsification of the content or appearance of this document is unlawful and offenders may be prosecuted to the fullest extent of the law.

Attention: To check the authenticity of testing /inspection report & certificate, please contact us at telephone: (86-755)83071443, or email: CN.Doccheck@sgs.com

Page No.: 7 of 11



Section 2: Production Process Control

2.1 Production Process Control		
Item	Content	Observations /Comments
1	Product R&D capacity	<input type="checkbox"/> Own brand <input type="checkbox"/> ODM <input checked="" type="checkbox"/> OEM
2	Are the environmental conditions, such as tidiness and cleanliness being controlled and suitable for the operation performed?	<input type="checkbox"/> Very tidy <input checked="" type="checkbox"/> Normal <input type="checkbox"/> Need to improve <input type="checkbox"/> Very poor
3	Are the necessary items /documents provided at appropriate location and under control?	<input type="checkbox"/> Work Instructions /procedures <input checked="" type="checkbox"/> Workmanship standard /acceptance <input type="checkbox"/> Golden sample /Approval sample <input type="checkbox"/> Product picture <input type="checkbox"/> Verbal by workshop director
4	Are written instructions available for incoming material inspections /testing? Is the relevant record maintained?	<input type="checkbox"/> Has instructions and uniformly followed <input checked="" type="checkbox"/> Has instruction but no written records <input type="checkbox"/> Materials checked by storage staff
5	Are written inspections /testing instructions available for finished products? Is the relevant record maintained?	<input type="checkbox"/> Have instructions and uniformly followed <input checked="" type="checkbox"/> Have instruction but no written records <input type="checkbox"/> Finished product checked by packing staff
6	What type of inspection is used for finished products?	<input checked="" type="checkbox"/> Random inspection <input checked="" type="checkbox"/> Visual inspection <input checked="" type="checkbox"/> Function inspection <input type="checkbox"/> 100% inspection <input type="checkbox"/> Visual inspection <input type="checkbox"/> Function inspection
7	Are non-conforming units clearly marked/ segregated to prevent accidental dispatch?	<input checked="" type="checkbox"/> Marked and segregated <input type="checkbox"/> Segregated but not marked clearly <input type="checkbox"/> Not found on site
8	How are the non-conforming units handled?	<input checked="" type="checkbox"/> Repaired and re-inspection <input type="checkbox"/> Picked out <input type="checkbox"/> Used under control <input type="checkbox"/> Others

This document is issued by the Company under its General Conditions of Service accessible at http://www.sgs.com/terms_and_conditions.htm. Attention is drawn to the limitation of liability, indemnification and jurisdiction issues defined therein. Any holder of this document is advised that information contained hereon is solely limited to visual examination of the safely and readily accessible portions of the consignment and reflects the Company's findings at the time of its intervention only and within the limits of Client's instructions, if any. The Company's sole responsibility is to its Client and this document does not exonerate parties to a transaction from exercising all their rights and obligations under the transaction documents. Any unauthorized alteration, forgery or falsification of the content or appearance of this document is unlawful and offenders may be prosecuted to the fullest extent of the law.

Attention: To check the authenticity of testing /inspection report & certificate, please contact us at telephone: (86-755)83071443, or email: CN.Doccheck@sgs.com



Part J: Photos

Section 1: Photos of Documents

1.1 Photos of Documents

Description: Business License



This document is issued by the Company under its General Conditions of Service accessible at http://www.sgs.com/terms_and_conditions.htm. Attention is drawn to the limitation of liability, indemnification and jurisdiction issues defined therein. Any holder of this document is advised that information contained hereon is solely limited to visual examination of the safely and readily accessible portions of the consignment and reflects the Company's findings at the time of its intervention only and within the limits of Client's instructions, if any. The Company's sole responsibility is to its Client and this document does not exonerate parties to a transaction from exercising all their rights and obligations under the transaction documents. Any unauthorized alteration, forgery or falsification of the content or appearance of this document is unlawful and offenders may be prosecuted to the fullest extent of the law.

Attention: To check the authenticity of testing /inspection report & certificate, please contact us at telephone: (86-755)83071443, or email: CN.Doccheck@sgs.com

Section 2: Photos of Company

2.1 Photos of Company and Product Sample

Description: Company Gate



Description: Company Name



Description: Office Building



Description: Office



Description: Workshop



Description: Workshop



This document is issued by the Company under its General Conditions of Service accessible at http://www.sgs.com/terms_and_conditions.htm. Attention is drawn to the limitation of liability, indemnification and jurisdiction issues defined therein. Any holder of this document is advised that information contained herein is solely limited to visual examination of the safely and readily accessible portions of the consignment and reflects the Company's findings at the time of its intervention only and within the limits of Client's instructions, if any. The Company's sole responsibility is to its Client and this document does not exonerate parties to a transaction from exercising all their rights and obligations under the transaction documents. Any unauthorized alteration, forgery or falsification of the content or appearance of this document is unlawful and offenders may be prosecuted to the fullest extent of the law.

Attention: To check the authenticity of testing /inspection report & certificate, please contact us at telephone: (86-755)83071443, or email: CN.Doccheck@sgs.com

Description: Workshop



Description: Workshop



Description: Warehouse



Description: Warehouse



-- End of the Report --

This document is issued by the Company under its General Conditions of Service accessible at http://www.sgs.com/terms_and_conditions.htm. Attention is drawn to the limitation of liability, indemnification and jurisdiction issues defined therein. Any holder of this document is advised that information contained hereon is solely limited to visual examination of the safely and readily accessible portions of the consignment and reflects the Company's findings at the time of its intervention only and within the limits of Client's instructions, if any. The Company's sole responsibility is to its Client and this document does not exonerate parties to a transaction from exercising all their rights and obligations under the transaction documents. Any unauthorized alteration, forgery or falsification of the content or appearance of this document is unlawful and offenders may be prosecuted to the fullest extent of the law.

Attention: To check the authenticity of testing /inspection report & certificate, please contact us at telephone: (86-755)83071443, or email: CN.Doccheck@sgs.com